

BUSH & WILTON

TAPERED BORE ROTARY AIRLOCK



MULTIPLEX RANGE MODEL MSR 'T' SERIES

www.bushandwilton.com



BUSH & WILTON

THE INNOVATIVE VALVE SPECIALISTS

TAPERED BORE ROTARY AIRLOCK MULTIPLEX RANGE - MODEL MSR 'T'

INTRODUCTION

Bush & Wilton Rotary Valves are designed for use under gravity, pressure and vacuum conditions.

They are suitable for metering a wide range of dry solids, granular, pelleted and powdered type materials from the outlets of silos, hopper, cyclones, mixers, weighers etc.

Rotary valves have to perform under diverse operating conditions and since no single design of valve can economically perform all duties Bush & Wilton have developed many rotary valve variants.

These are, as outlined on our introductory leaflet, which in standard form are suitable for applications where pressure differentials do not exceed 1.0 Bar, heavy duty versions of the valve are available for use with difficult materials and higher pressures. See our 'IFU' leaflet.

The MSR 'T' tapered rotor range for pressure differentials not greater than 0.6 Bar and the dust collection valve range specifically developed for discharging dust collectors and cyclones, etc. at a max. of 0.3 Bar.

The standard taper rotor is of the closed-end type with matching bore in the valve body.

The valve is suitable for handling the majority of dry powdered and granular type materials in its standard form.

The radial running clearances between rotor and body are simple to adjust and can be set to suit the product being metered.

When there is a differential pressure across the valve, such as in pneumatic conveying systems, gas losses through the valve can be minimised.

When the product being metered is at a higher or lower temperature than ambient, clearances can be set to compensate for differential expansion between the valve body and rotor.

Re-assemble after routine maintenance is simple since the rotor need only be pushed into the valve body, the end covers and seals are then fitted.

Radial clearances are set by withdrawing the rotor using the locking collars.

These collars are tightened each side of the relevant outboard bearing once the setting has been achieved.



Tapered Rotary Valve

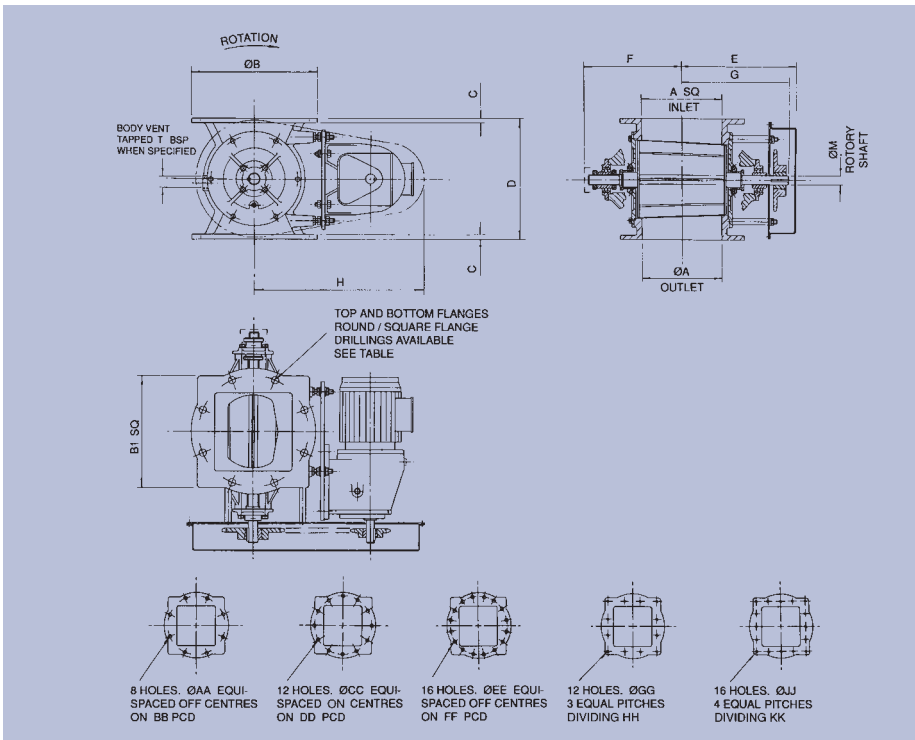

SR SERIES

The Bush & Wilton 'SR' range of Rotary Valves has been designed so that they can, dependant on flange drilling, be installed on either square or round flanges without transitions.

The 'SR' valve is manufactured in six sizes 150mm, 200mm, 250mm, 300mm, 350mm and 400mm.

OPTIONS

- Quick Release Rotors
- Direct Coupled Drives
- Air Purge Glands
- Body Vents
- Vent Boxes
- Dropout Boxes
- V.S. Drives
- Speed Switches
- Flameproof Motors
- Shear Plate Deflectors
- Electroproof Nickel Plating
- Tungsten Carbide Internals etc.

Valve Size	ØA	ØB	B1sq	C	D	E	F	H	T	ASA150						SQUARE				Wt KG	KW
										AA	BB	CC	DD	EE	FF	GG	HH	JJ	KK		
MSRT15	150	280	240	12	270	297	263	391	3/4" BSP	22	241					14	210			80	.37
MSRT20	200	343	292	13	320	330	278	406	3/4" BSP	22	299					14	254			100	.37
MSRT25	250	406	362	13	381	360	341	530	1" BSP			25	362			14	318			145	.75
MSRT30	300	483	419	17	420	375	357	530	1" BSP			25	432			14	368	195		195	.75
MSRT35	350	533	457	20	500	420	383	607	1 1/2" BSP			29	476			14	419	265		265	.75
MSRT40	400	597	526	22	550	446	408	607	1 1/2" BSP					29	540	19	476	335		335	1.1

Bush & Wilton Limited 5/6 Millennium Place, Tiverton, Devon EX16 6SB

Tel: 01884 242233 Fax: 01884 252555

E-mail: sales@bushandwilton.co.uk www.bushandwilton.com