

BUSH & WILTON

PARALLEL BORE ROTARY AIRLOCK



MULTIPLEX RANGE MODEL MSR 'P' SERIES

www.bushandwilton.com



BUSH & WILTON

THE INNOVATIVE VALVE SPECIALISTS

PARALLEL BORE ROTARY AIRLOCK MULTIPLEX RANGE - MODEL MSR 'P'

INTRODUCTION

The prime function of a rotary valve is to regulate the flow from one chamber to another while maintaining a good airlock condition. The product is mainly in dry powder or granular form.

In the dust filtration field good airlocks are essential on cyclone and bag filter applications in order that the manufacturer's quoted high dust collection efficiencies can be maintained. Airlocks are also important in the pneumatic conveying industry, where the product is regulated into a high pressure conveying line while minimising air leakage.

With Bush & Wilton there are no double standards, all our standard valves are precision machined for close tolerances and minimal eccentricities. Pressure differentials to 20psi and temperatures to 400°C.

We have made specials to handle temperatures covering 1200°C and pressures to 350psi.

STANDARD FEATURES

- Maximum number of blades in contact with body at one time without affecting throughput.
- Good throat opening at valve entry allowing high pocket filling efficiency.
- Minimum clearance at rotor tips and sides with body.
- Robust body adequately stiffened to prevent distortion.
- Heavy shaft diameters minimising deflection.
- Outboard bearings for non-contamination.
- Packing gland type seals.
- Maximising valve speed to 25 rpm - prolonging life, ensuring good throughput.
- Precision machining of components.

All add up to BUSH & WILTON standards.

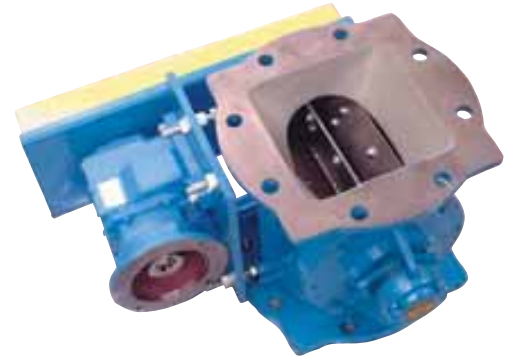

SR SERIES

The Bush & Wilton 'SR' range of Rotary Valves has been designed so that they can, dependant on flange drilling, be installed on either square or round flanges without transitions.

The 'SR' valve is manufactured in six sizes 150mm, 200mm, 250mm, 300mm, 350mm and 400mm.

SPECIFICATION

Bodies Cast Iron, Stainless Steel or Aluminium precision bored.

End Covers Cast Iron, Stainless Steel or Aluminium spigot located in body for concentricity.

Rotor Fabricated Mild or Stainless Steel.

Bearings Sealed for life ball type rigged outboard or high temperature above 250° C.

Shaft Seal Gland type with PTFE packing.

Drive TEFC geared motor unit side wall mounted to valve body and complete with taper lok sprockets chain drive all in an enclosed guard.

OPTIONS

- Quick Release Rotors
- Direct Coupled Drives
- Air Purge Glands
- Body Vents
- Vent Boxes
- Dropout Boxes
- V.S. Drives
- Speed Switches
- Flameproof Motors
- Shear Plate Deflectors
- Electroproof Nickel Plating
- Tungsten Carbide Internals etc.

VALVE SELECTION

Please refer to our chart within the binder which gives an example.

The chart gives theoretical and practical throughput on the basis of rotor speeds.

The theoretical efficiency is seldom achieved in practice as density, product characteristics pressure differentials, feeding methods etc., all affect valve throughput.

On this basis the practical figures are assessed and are more acceptable for correct valve selection.

e.g. Select a valve to handle 7000 kg/hr of product at a bulk of 560 kgs / cubic metre.

$$\text{Volume of valve required} = \frac{7000}{560} = 12.5 \text{ cu m / hr.}$$

Two valves economically achieve this 200 @ 26 RPM and 300mm @ 12 RPM (refer to chart).

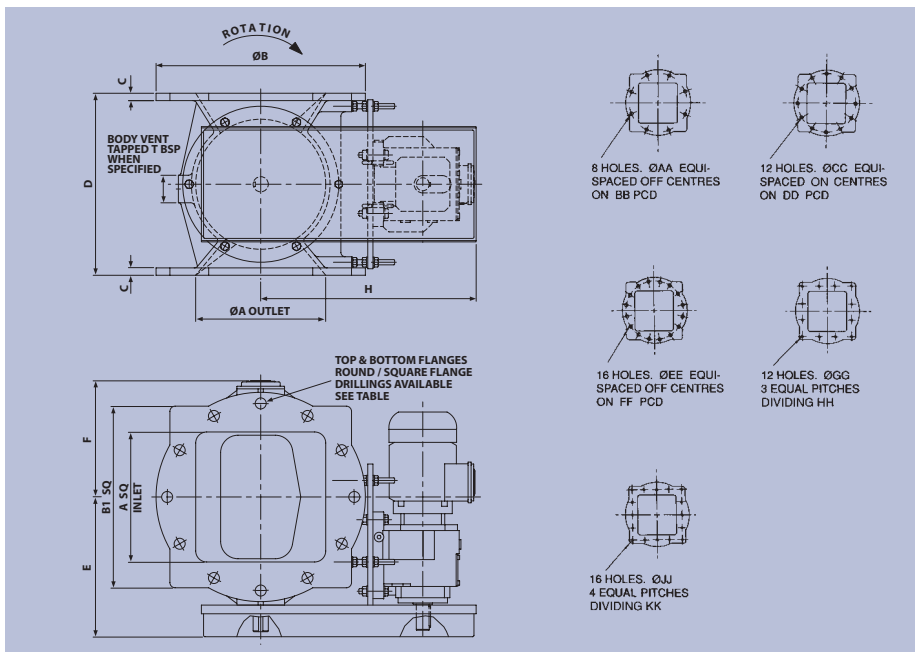

Valve Size	ØA	ØB	B1sq	C	D	E	F	H	T	ASA150				SQUARE				Wt KG	KW	
										AA	BB	CC	DD	EE	FF	GG	HH			JJ
MSRP15	150	280	240	12	270	257	194	378	3/4" BSP	22	241				14	210			80	.37
MSRP20	200	343	292	13	320	282	219	406	3/4" BSP	22	299				14	254			100	.37
MSRP25	250	406	362	13	381	315	252	478	1" BSP			25	362		14	318			145	.75
MSRP30	300	483	419	17	420	331	269	497	1" BSP			25	432				14	368	195	.75
MSRP35	350	533	457	20	500	377	294	579	1 1/2" BSP			29	476				14	419	265	.75
MSRP40	400	597	526	22	550	419	337	626	1 1/2" BSP					29	540		19	476	335	1.1

Throughput

Certain products when fluidised can greatly exceed the conservative rating and on application, e.g. cement, 100% pocket fillage has been known to occur - similarly light products up to 15lb/cu.ft.the opposite effect can happen.

Temperature

Note: On any application above ambient (21°C) it is important to specify operating temperatures so rotor compensation for expansion can be adjusted as necessary.

Bush & Wilton Limited 5/6 Millennium Place, Tiverton, Devon EX16 6SB

Tel: 01884 242233 Fax: 01884 252555

E-mail: sales@bushandwilton.co.uk www.bushandwilton.com