



BUSH & WILTON

LIMITED

Materials Handling Equipment



ROTARY  **SLIDE**  **DIVERTER**  **PINCH**  **NI-HARD** 

www.bushandwilton.com



Rotary High Pressure Series



Rotary IF Series



Rotary OF Series



Rotary BS Series



Rotary SR Series

BUSH & WILTON

Rotary Valves

Designed for use in gravity vacuum and pressure conveying systems, Bush & Wilton Rotary Valves are suitable for metering a wide range of dry solids, granular, pelleted and powdered materials from the outlets of silos, hoppers, cyclones, mixers and weighers. We offer a choice between heavy duty parallel rotor feeders and a tapered rotor series suitable for lower differential pressures.



Slide Valves

There are six series of Slide Valve in our portfolio, ranging from manual economy models for gravity applications to pneumatically operated dust and gas tight constructions. All types are designed for superior performance without jamming or loss of sealing characteristics. We can tailor designs to suit individual needs, always with product protection and operating reliability in mind.

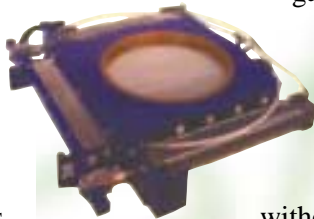

Diverter Valves

Our Diverter Valve range comprises a wide variety of construction options, actuations and applications. Utilising sealed flap, rotary plug, slidegate or pinch valve methods in cast and fabricated bodies, a diversity of powdered and granular products can be handled in gravity, pressure and vacuum driven environments. The Box Slider variant is of particular interest where a minimum of product degradation and component wear is critical.



Molten iron being poured into a Diverter Valve's mould.



Rotary SRD Series



Rotary SBT Series



Rotary SBC Series



Rotary SBS Series



Slide SMB Series



Diverter DG Series



Pinch NH Series

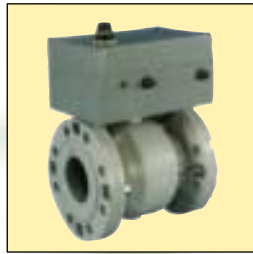

Pinch AK Series



Ni-Hard Pipes



A future full of challenge

Pinch Valves

Both our inline Pinch Valves offer a smooth internal profile suitable for powders, granules, slurries, liquids and gases in gravity,



pressure and vacuum conveying ducts and pipelines. They are easily installed and require minimal maintenance. The

hand operated anvil type closes a reinforced rubber sleeve by pinching it, while compressed air or suitable fluid accomplishes a bubble tight seal on a heavy duty elastomer sleeve in the pneumatic version.



Each valve component must pass stringent quality controls.

Ni-Hard Pipes

To cope with a whole list of abrasive materials such as sand, cement, quarry dust, granite dust, sinter dust, slag, coal and myriad, which cause extra wear on pipe-bends of conventional material, we provide a range of Ni-Hard castings, standard and special radius plain bends with replaceable wear-back plates and 'saddle-back' in-service repair attachments for plain bends and 'T' and 'Y' branches.

Available with plain or flanged ends, Bush & Wilton Ni-Hard bends are essential for the efficient conveying of abrasive materials.



Stocks

Our storage shelves carry comprehensive reserves of every valve described in this brochure. We feel confident that almost any requirement of the materials handling industry can be met in the shortest possible time. Whatever the requirement, our agents throughout the world have access to these stocks, as well as Bush & Wilton's specialist engineering experience, promising you reliable advice and prompt delivery.

*Bush & Wilton,
200 years of
experience
enabling us to
face a future full
of change.*



Stock control enables emergency items to be rapidly dispatched.



Slide RBTC Series



Slide FB Series



Diverter DMF Series



Diverter DBS Series



Diverter DP Series

A history of achievement . . .

Bush & Wilton began as a foundry some 200 years ago and was associated with the areas greatest engineering achievements. It has been claimed that the cast iron keel plates for Brunel's SS Great Britain were cast in the foundry.

Demand for machining facilities for jig and tool castings being produced for the local aircraft and aero engine factories led to the establishment of a large fully equipped machine shop.

Also in the 1950's involvement with local industries, particularly the tobacco factory, brought its initial involvement into Bulk Handling in which it eventually focused and flourished.

The Company purchased F & R Valves which specialised in Slide Valves and its unique Tapered Rotary Valve.



Molten iron being poured into a Diverter Valve's sand mould.

Bush & Wilton already had an extensive range of heavy duty valves and was well established supplying the Plastic and Petrochemical industries and supplied valves throughout the World for varied tasks in the most arduous conditions and for many of the foremost names in the Process Industry.

This brochure shows just a glimpse of the Company's standard range in this niche market, but our engineers and designers are at your call should a "special" application need a tailor made approach.



BUSH & WILTON

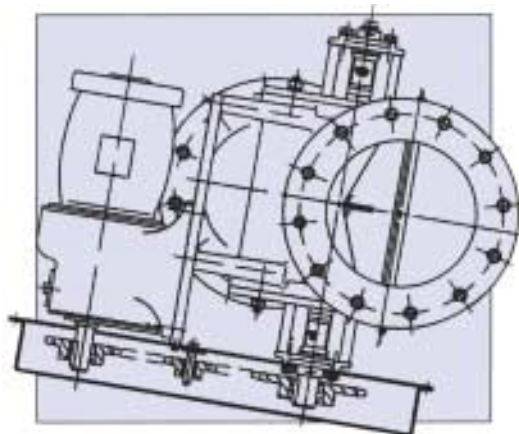

Bush & Wilton Limited

6 Millennium Place, Tiverton Business Park
Tiverton, Devon EX16 6SB

Tel: 01884 242 233 Fax: 01884 252 555

E-mail: sales@bushandwilton.com

Website: www.bushandwilton.com